

Sunne sängar

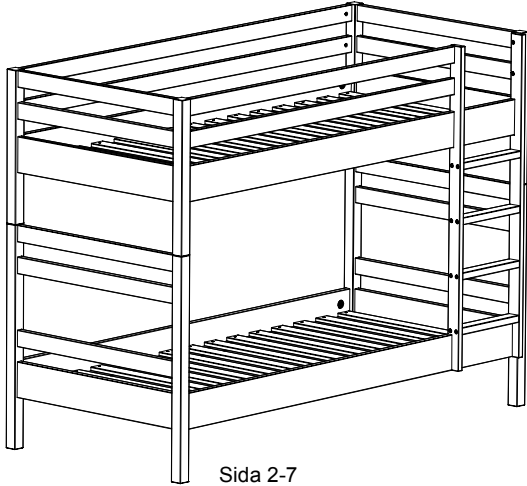

Sida 2-7

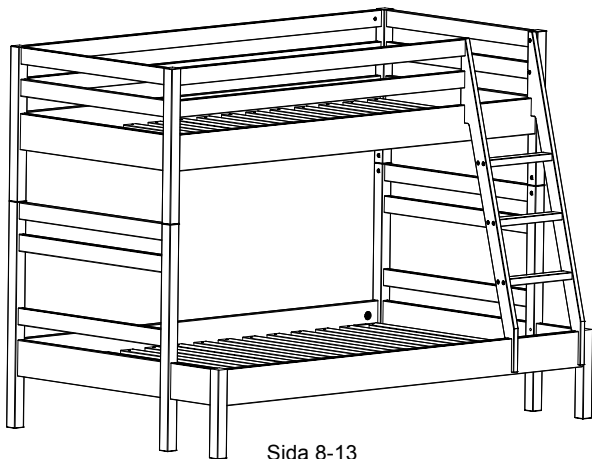

Sida 8-13

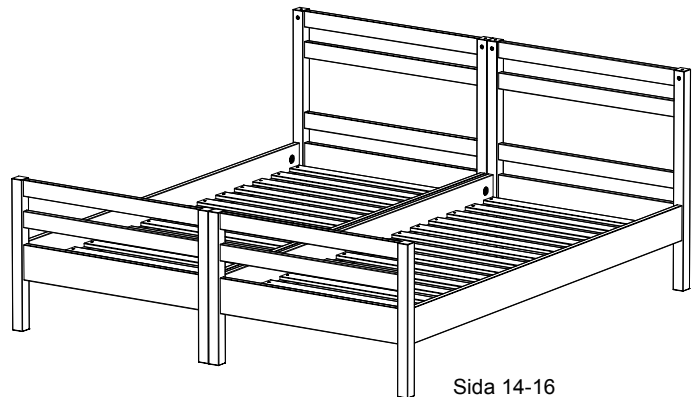

Sida 14-16

Säkerhetsinstruktioner.

Barn under 6år bör ej använda översäng på grund av fallrisk.

Häng aldrig snöre / remmar i sängen på grund av stryplingsrisk.

Varning! Barn kan klämmas mellan sängen och väggen, för att undvika detta ska sängen stå mindre än 75mm eller mer än 230mm från väggen.

Använd aldrig sängen om den har skador eller saknar beslag.

Kontrollera skruvförband med jämna mellanrum.

Rekommenderad madrassstorlek **90x200cm**.

Max madrassjocklek översäng 19cm. På stegen finns ett märke som visar max madrassjocklek.

Överensstämmer med **EN 747-1:2007**.

Innan du börjar.

Läs igenom monteringsanvisningen och kontrollera beslag och delar.

Se till att ha en bra yta att jobba på.

Ta fram behovet av verktyg.

Bestäm stegens placering, vänster alt höger innan ni börjar montera.

Spara monteringsanvisningen för framtida behov.

Sunne Våningssäng



Delar Våningssäng.

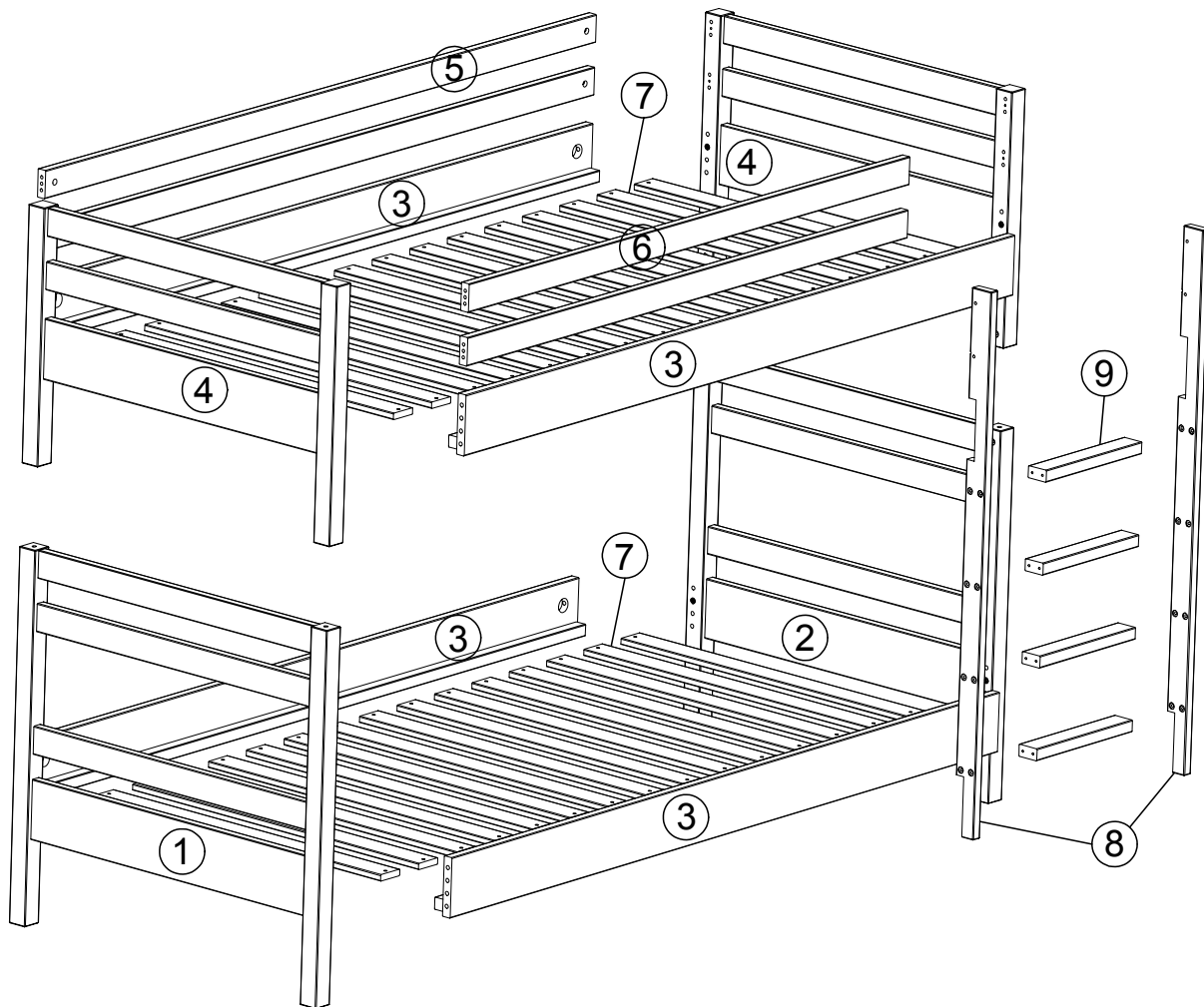

Verktögsbehov.

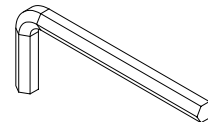
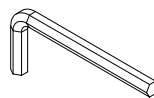
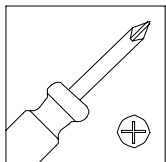

Beslag.

Ax24



Bx12



Cx8

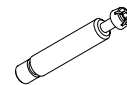

Dx8



Ex6



Fx6



Gx60



Ix8



Jx4

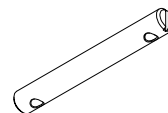

Kx18

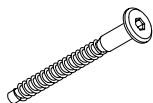

Lx2



Mx3

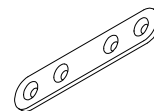

Nx12



Ox2

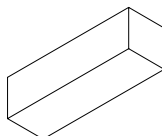

MAVIS®

1. (x2)

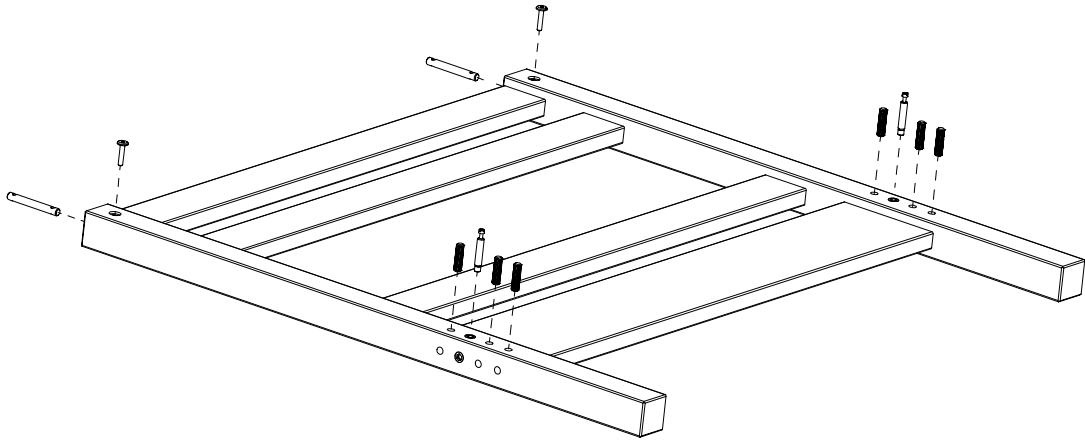

2. (x4)

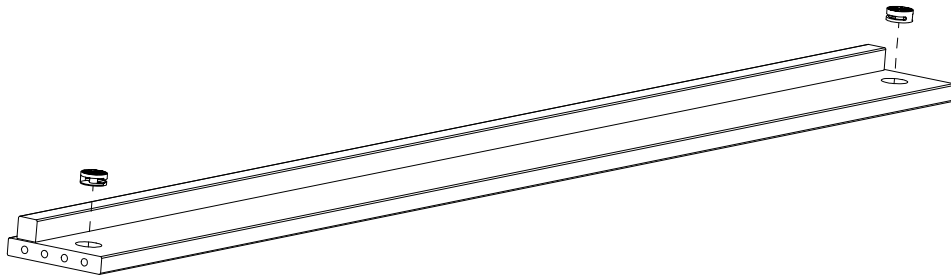

3.

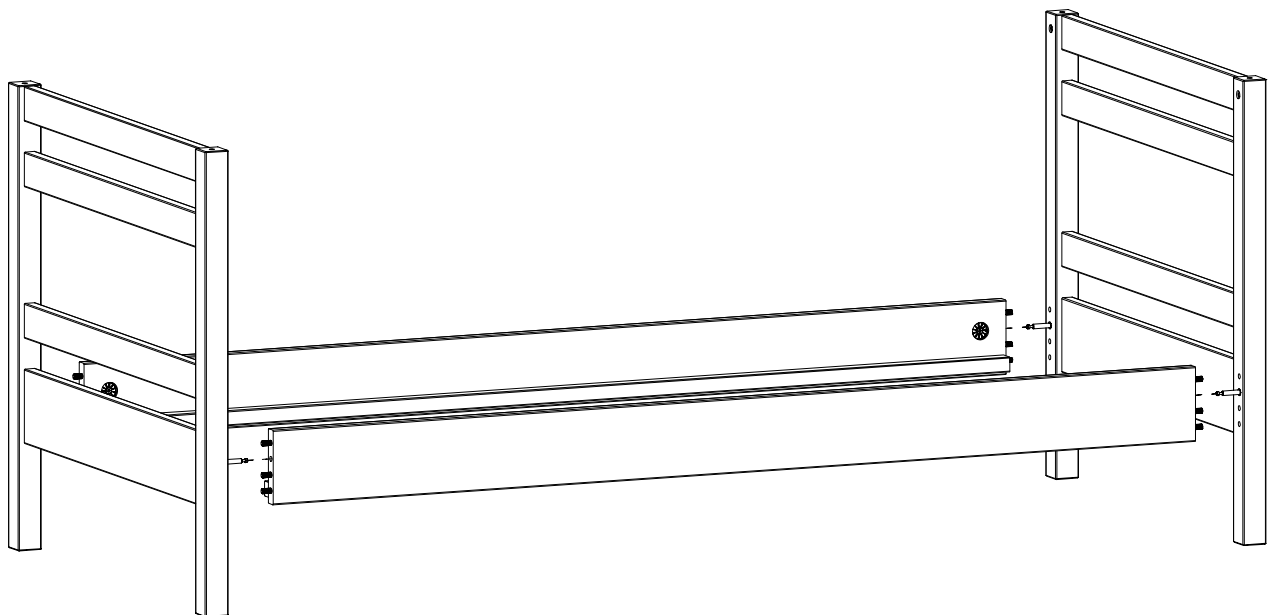

4.

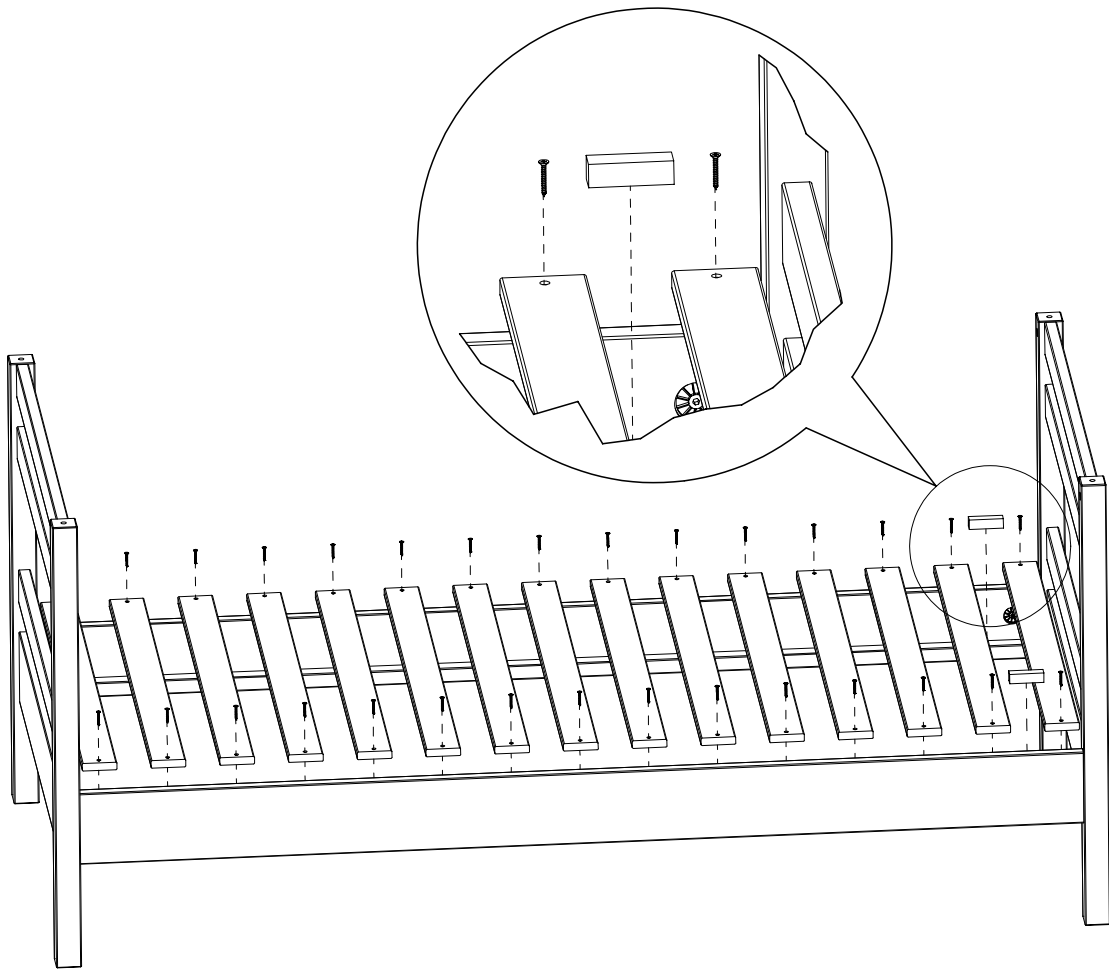
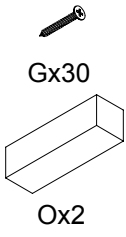

5.

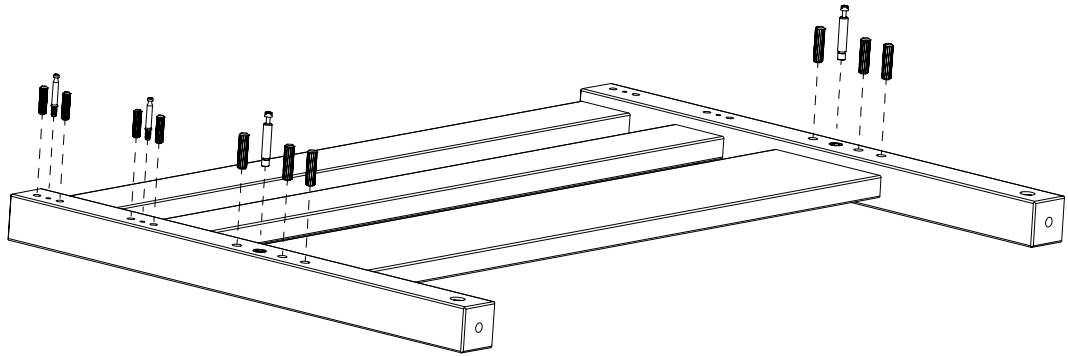

6.

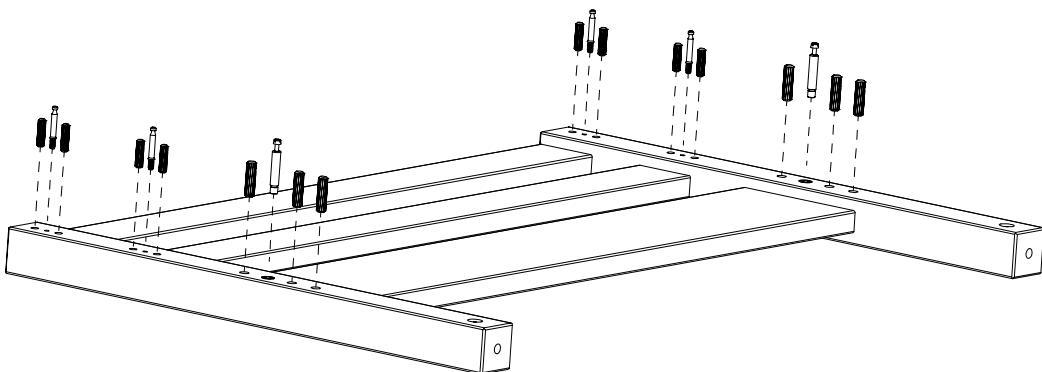
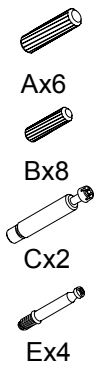

7. (x2)



Fx2

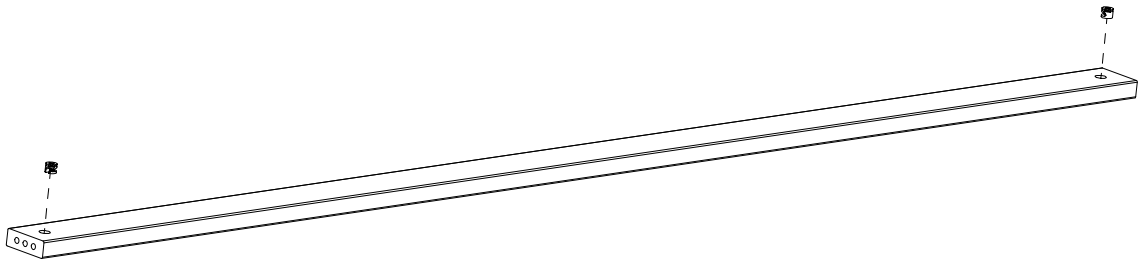

8.

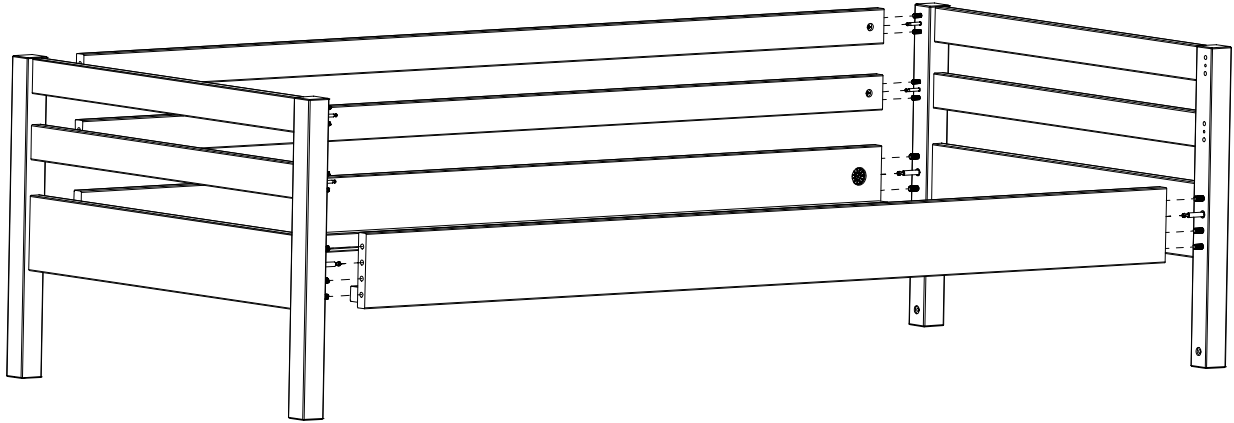

9.



Gx30

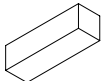

Ox2

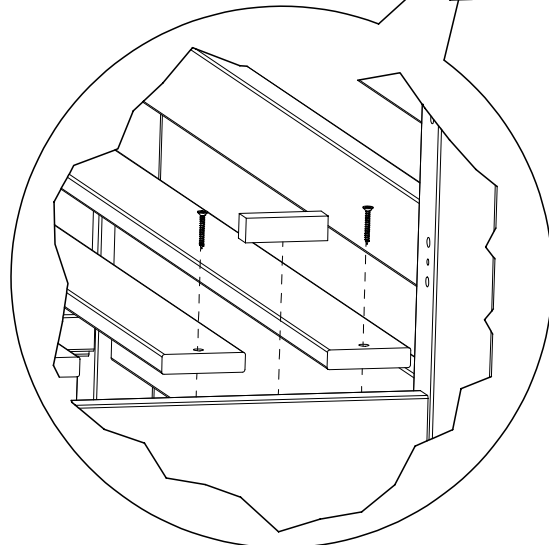
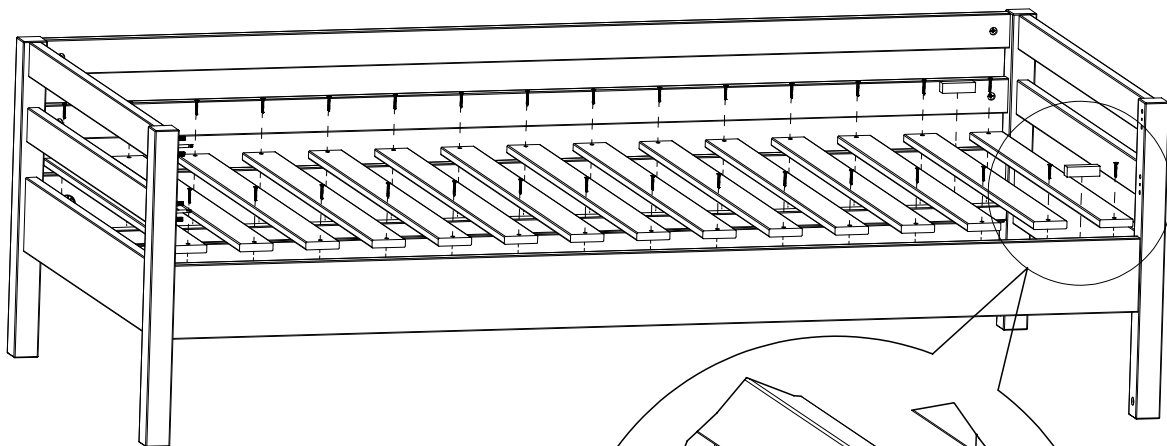

MAVIS®

10.



1x4

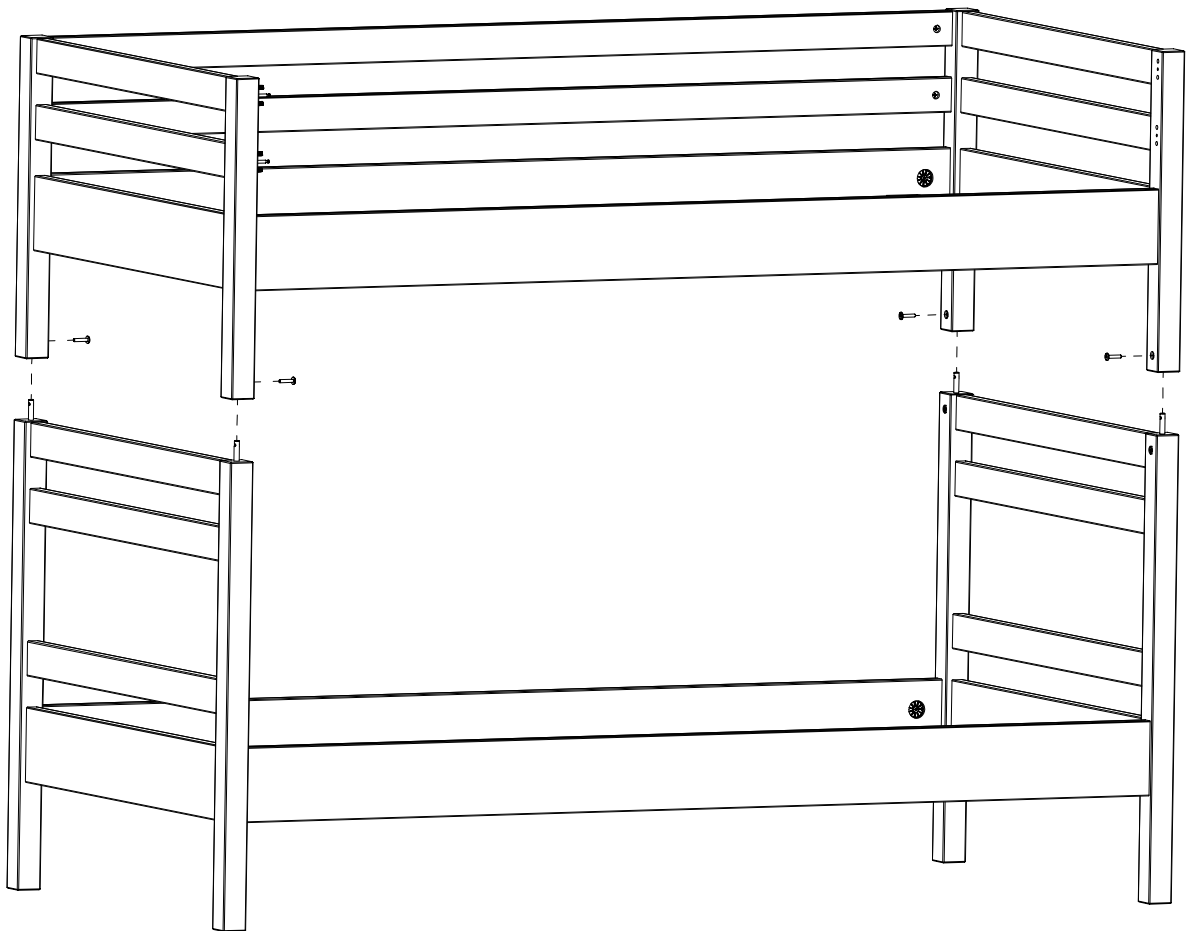

11.



Fx2

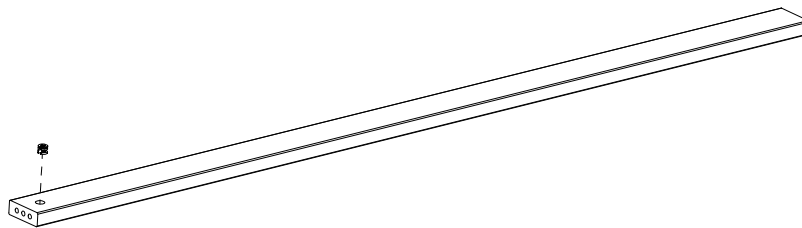

12.

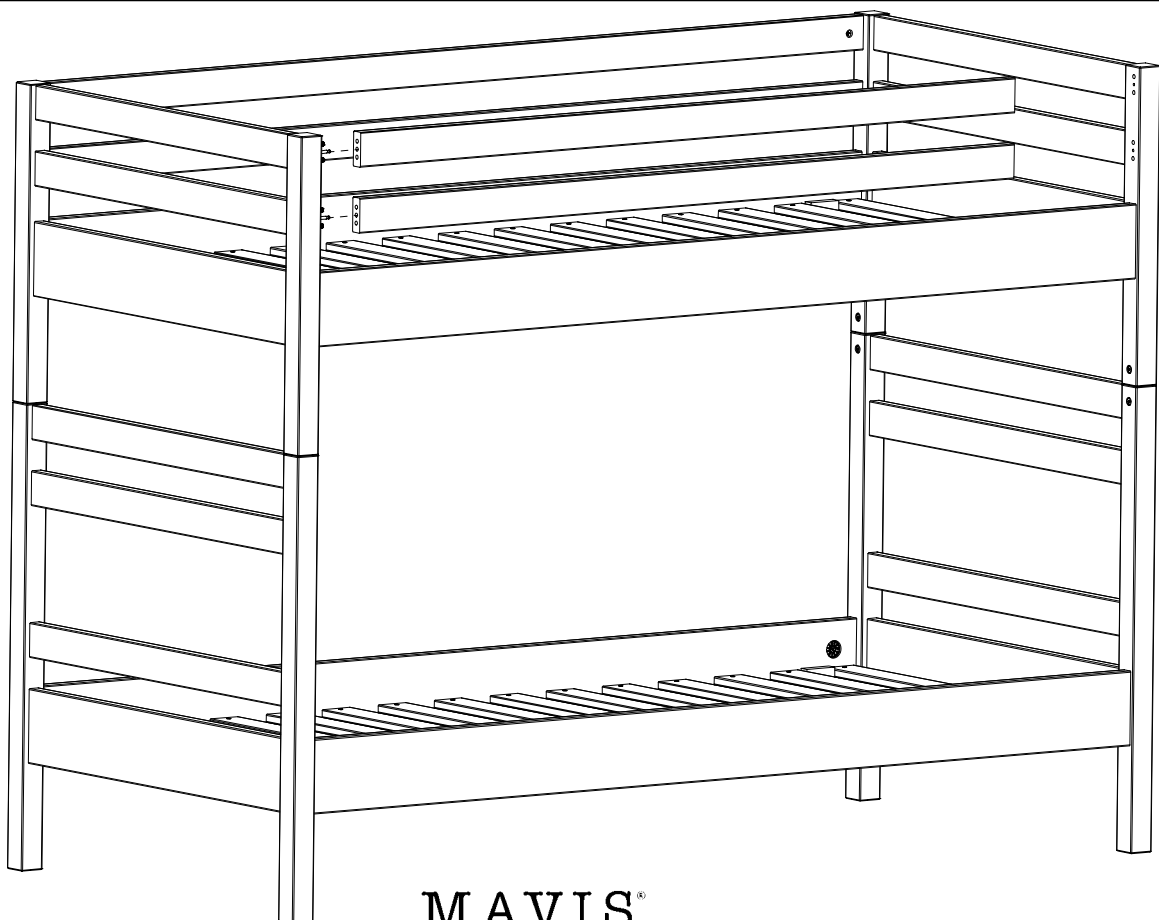

MAVIS®

13.

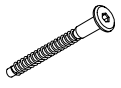

Kx16

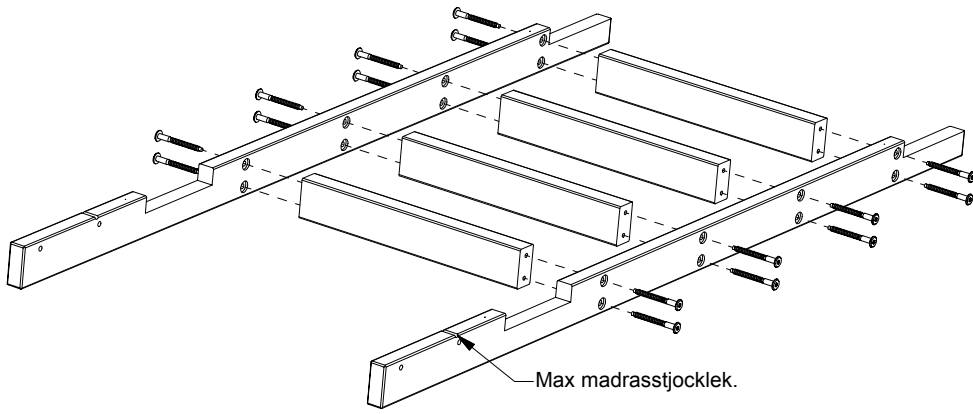

Max madrassstjocklek.

14.



Kx2



Lx2

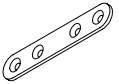

Lx3



Lx12

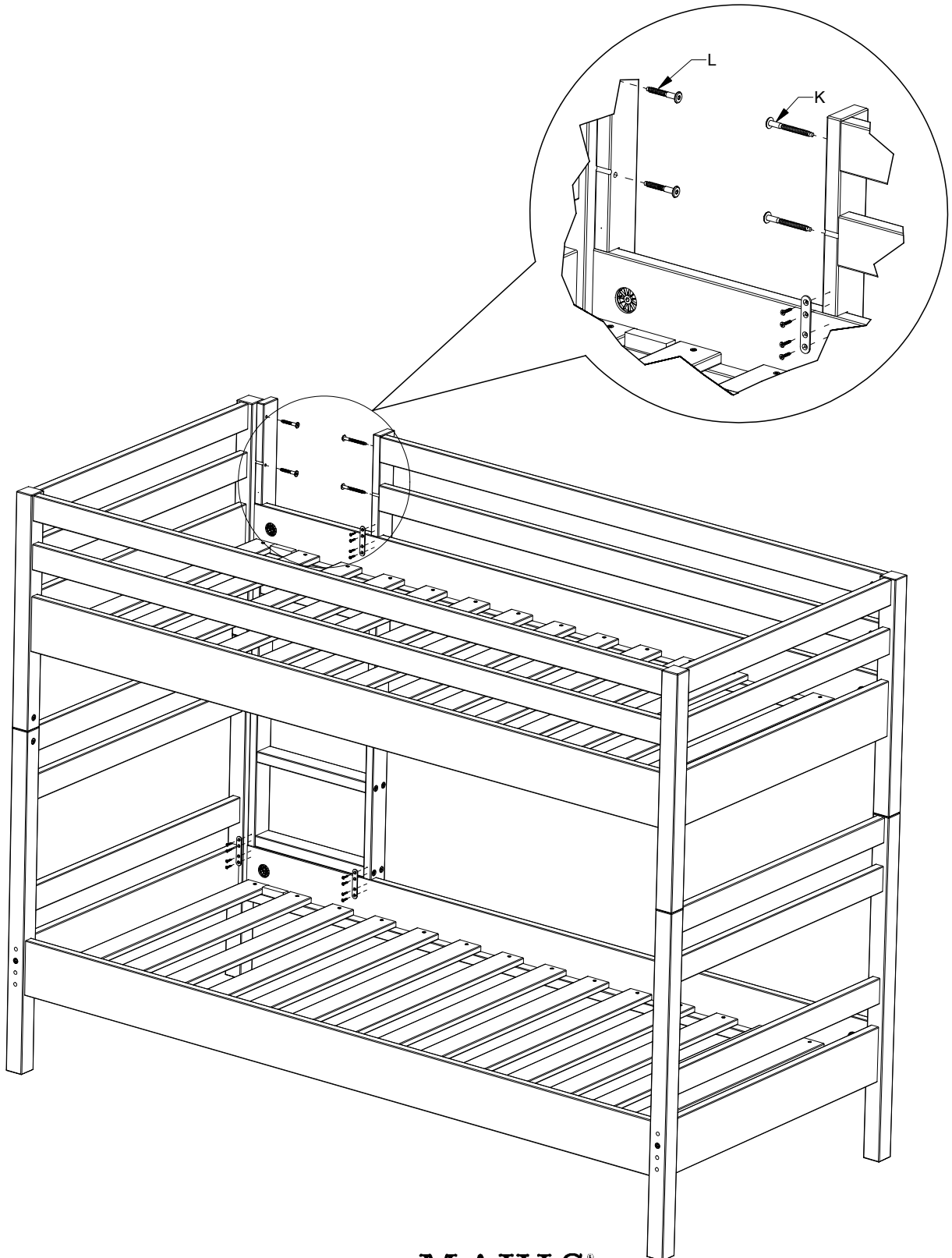

MAVIS®

Sunne Familjesäng

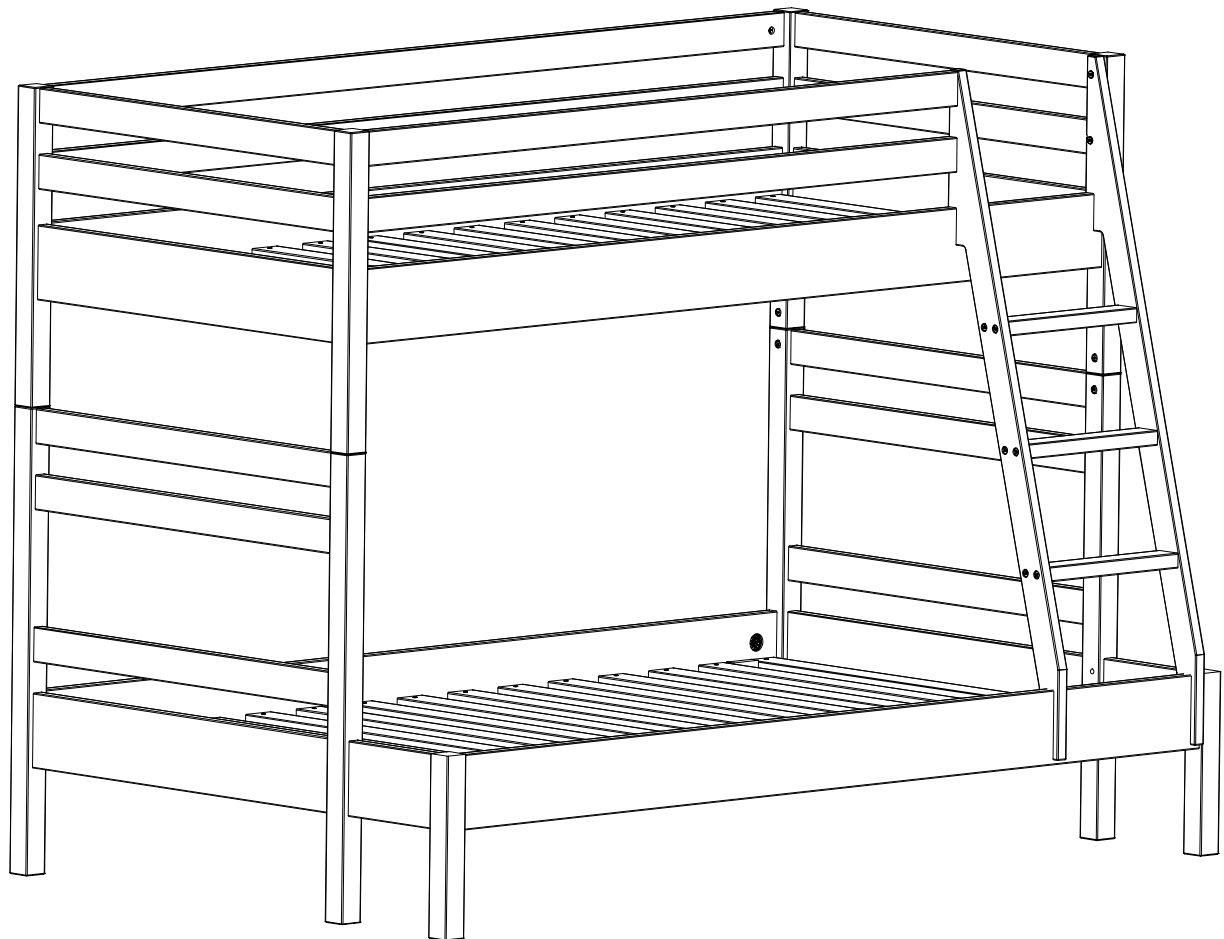

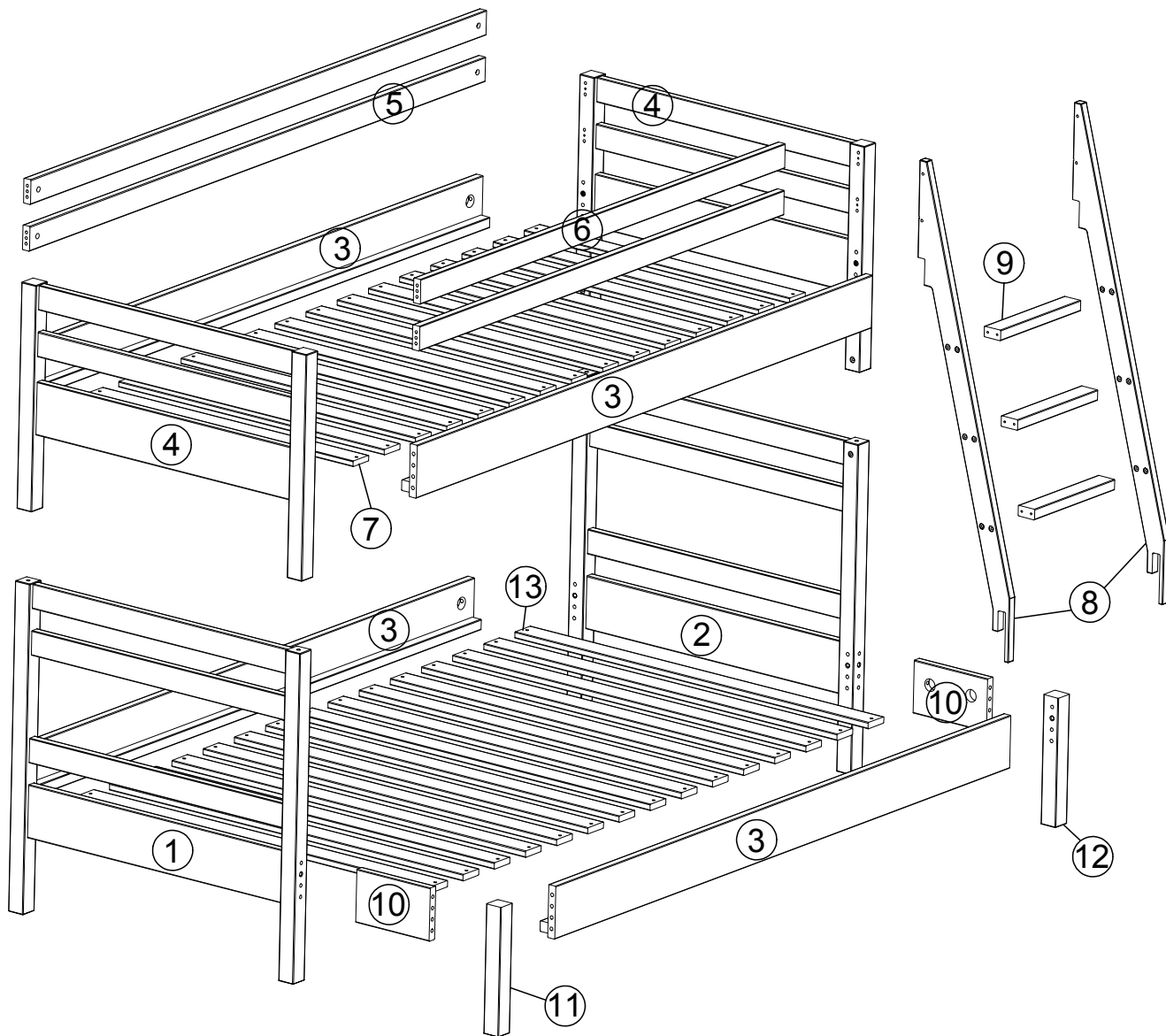

Verktysbehov.

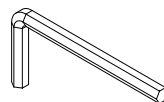
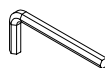
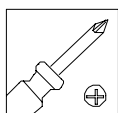

Beslag.

Ax36



Bx12



Cx12



Dx12



Ex6



Fx6



Gx60



Hx8



Jx4

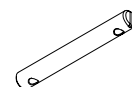

Kx14



Lx2



Mx1

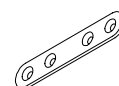

Nx4



Ox2

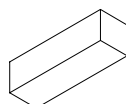

MAVIS®

1. (x2)

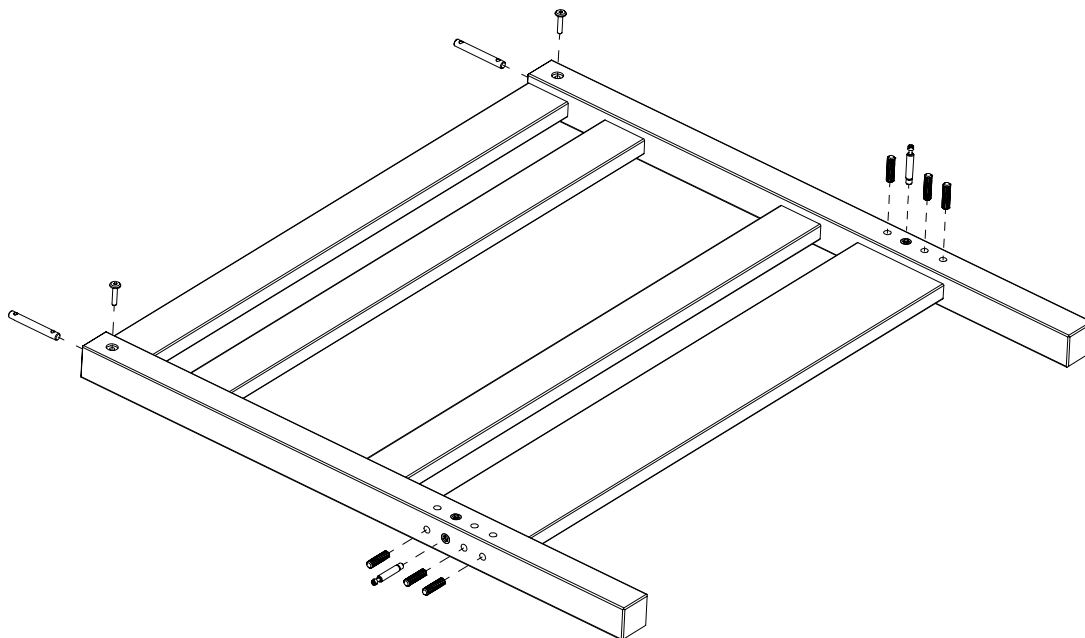

2. (x2)

Observera att benen är olika på höger och vänster sida.

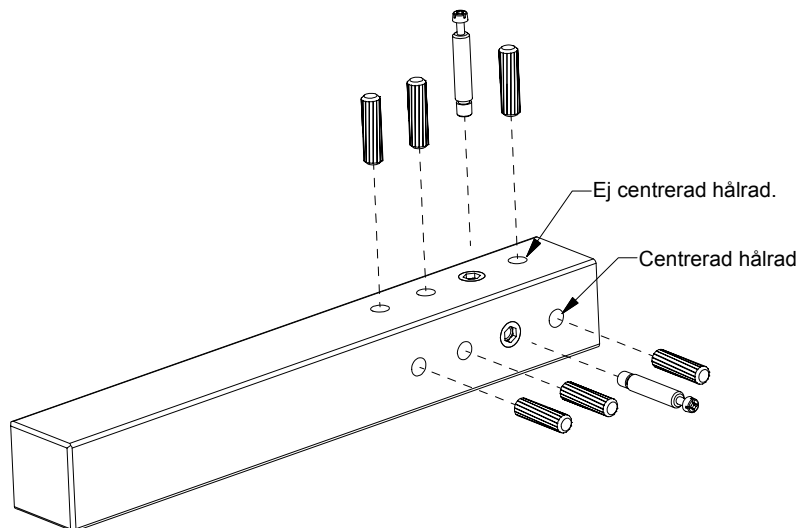
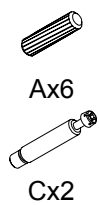

3. (x2)

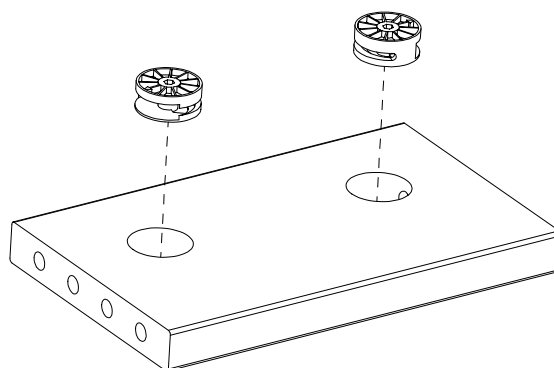

4. (x2)

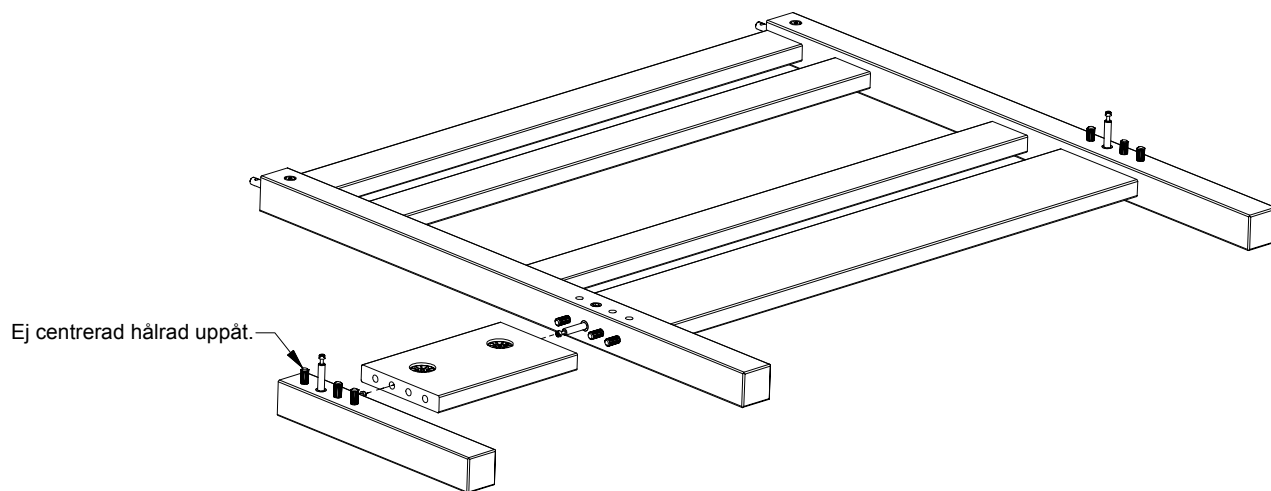

5. (x4)



Dx2

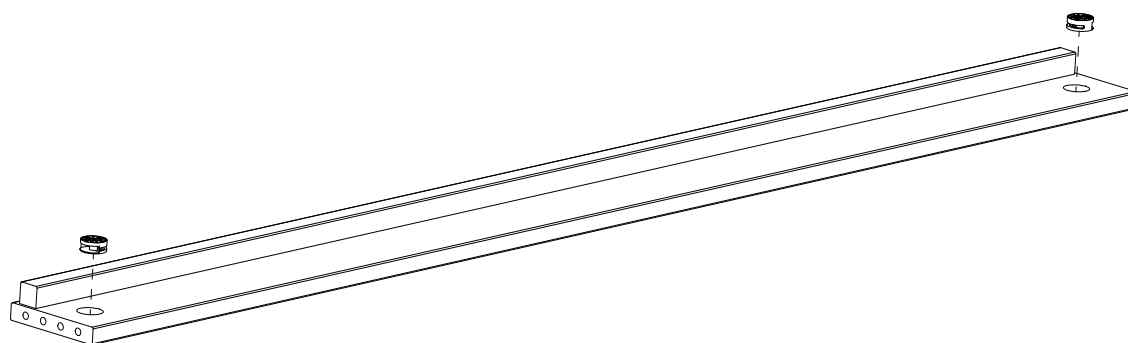

6.

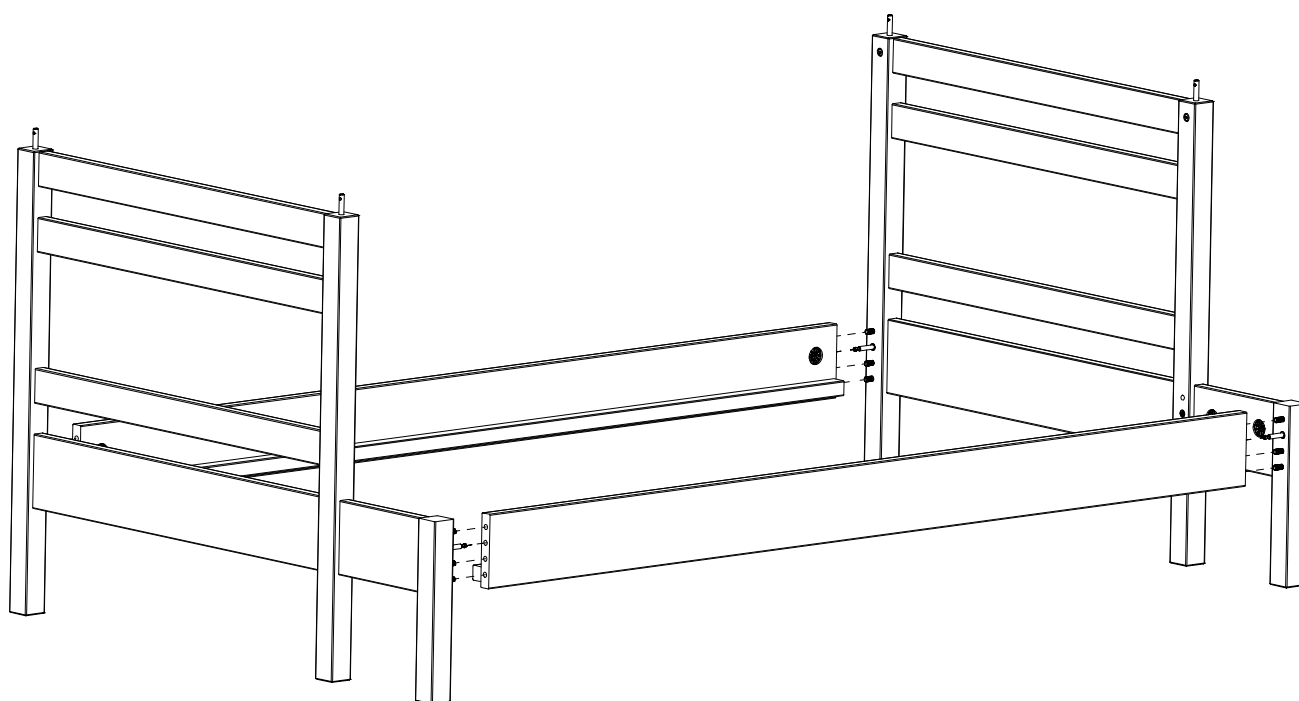

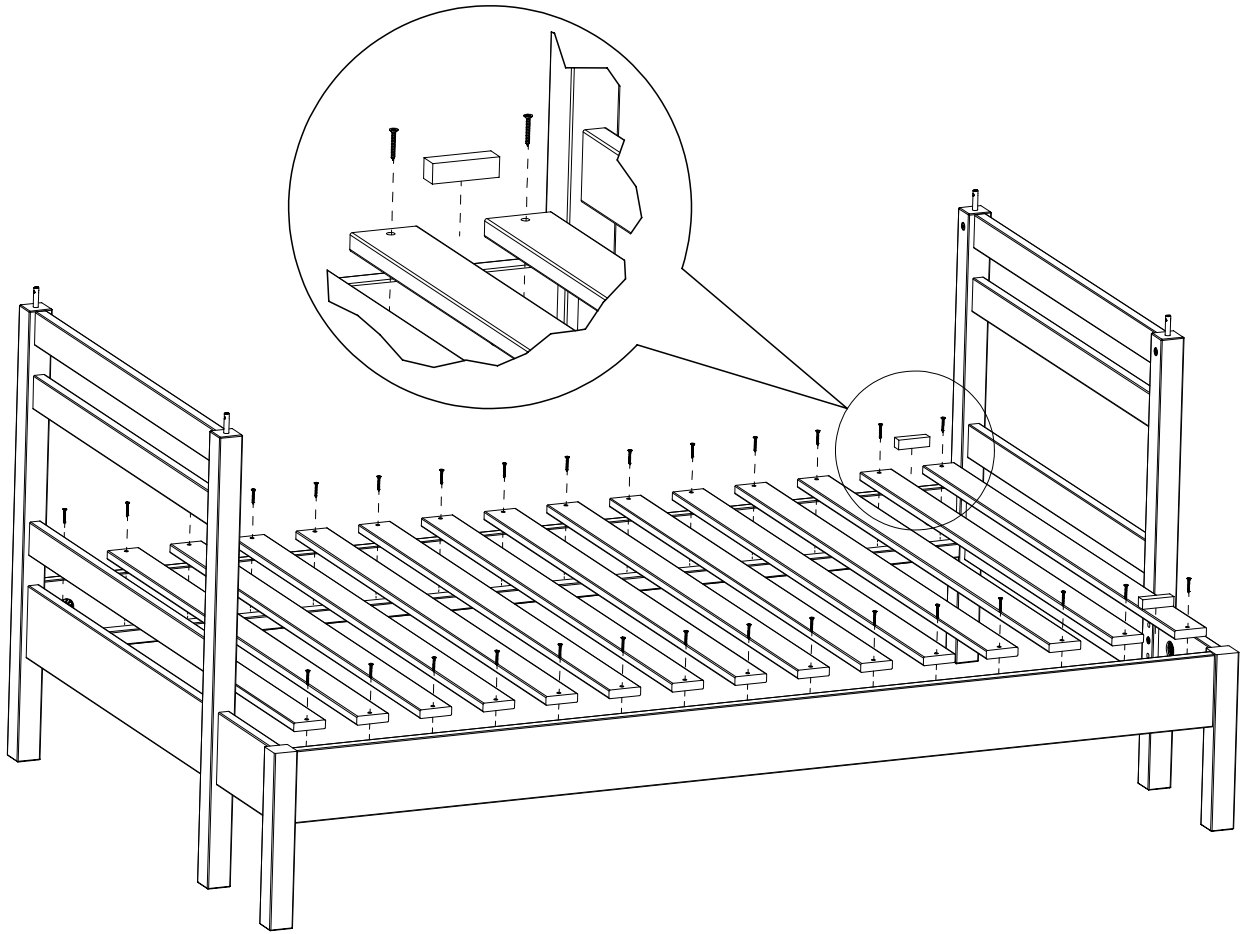

7.

-  Gx30
-  Ox2





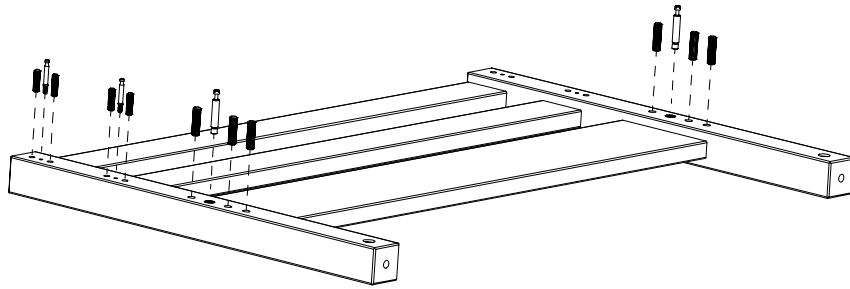

8.

-  Ax6
-  Bx4
-  Cx2
-  Ex2



9.

-  Ax6
-  Bx8
-  Cx2
-  Ex4

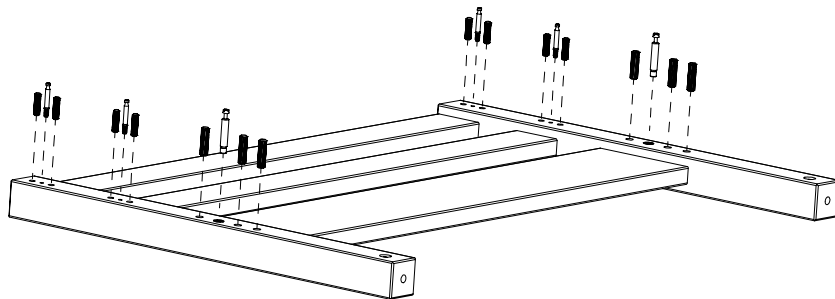

10. (x2)

-  Fx2

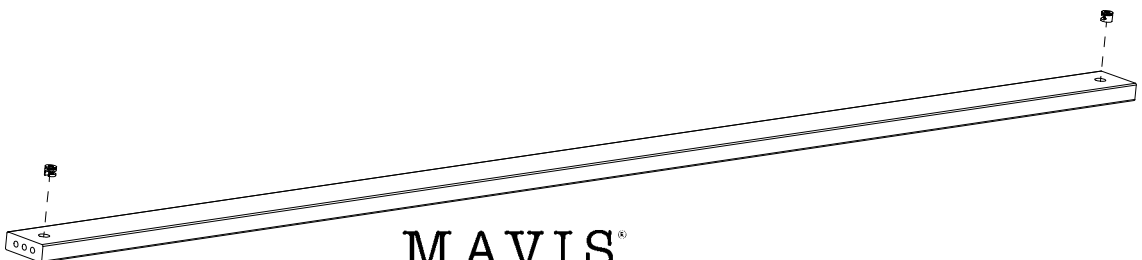

MAVIS®

11.

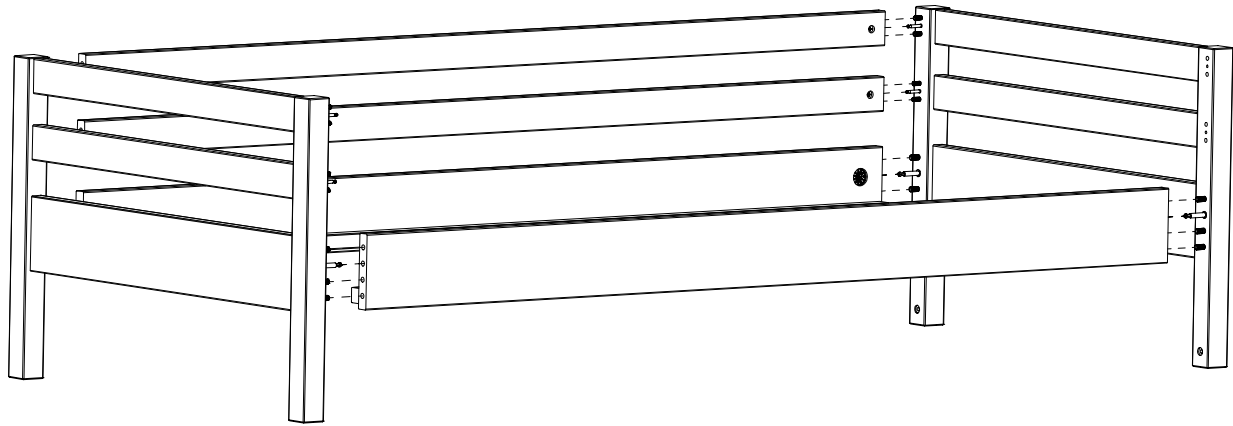

12.



Gx30



Ox2

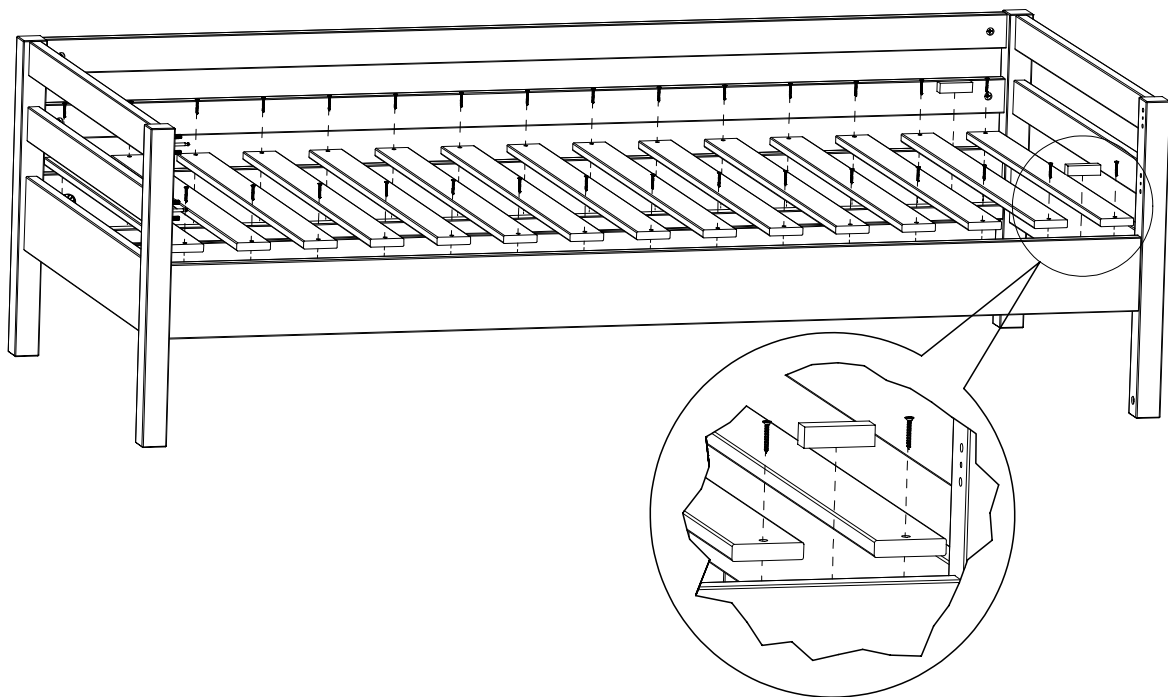

13.



Hx4

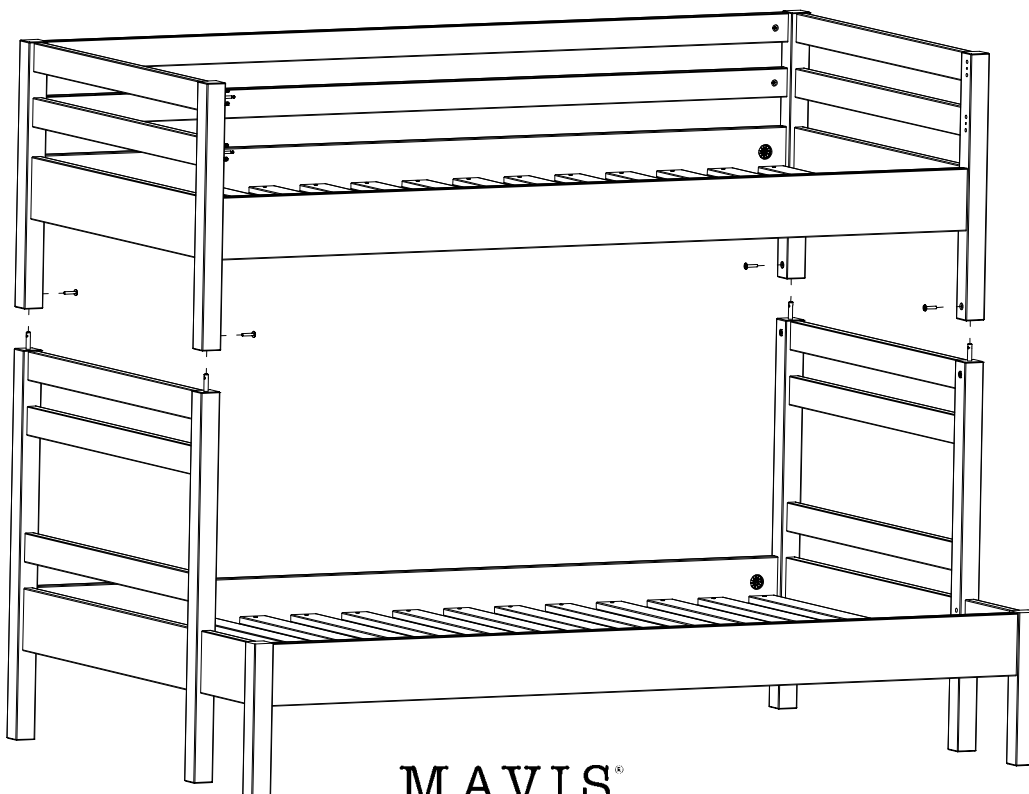

MAVIS®

14.

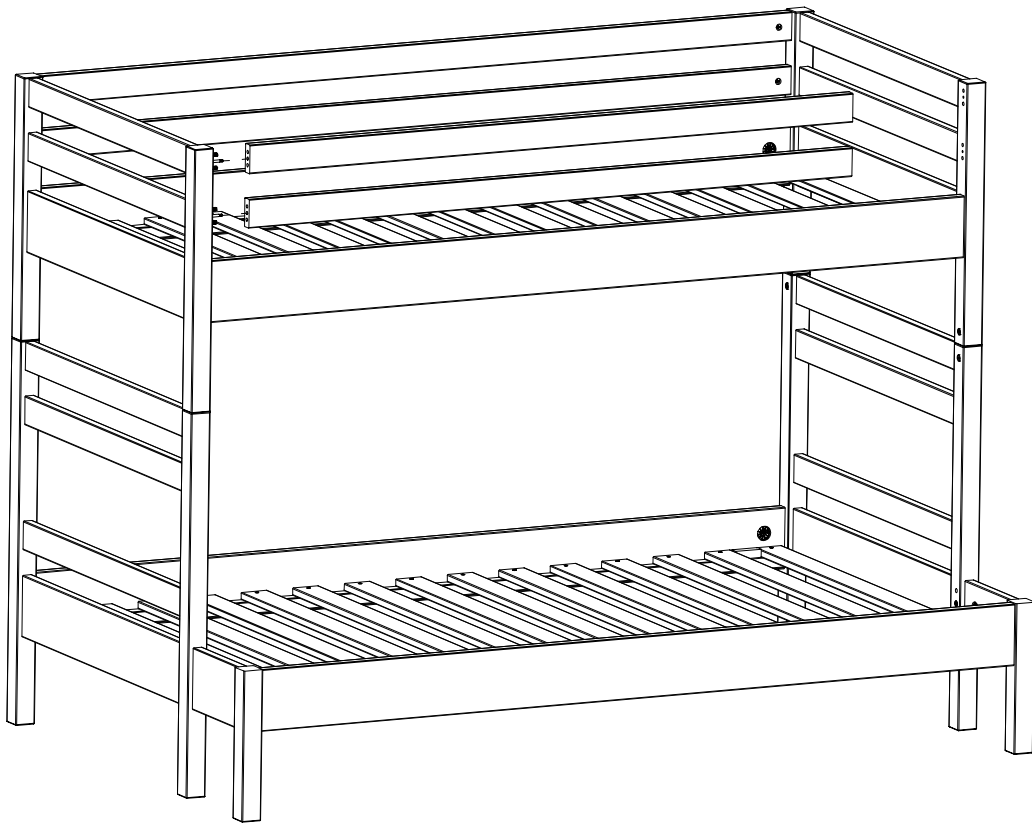

15.



Kx12

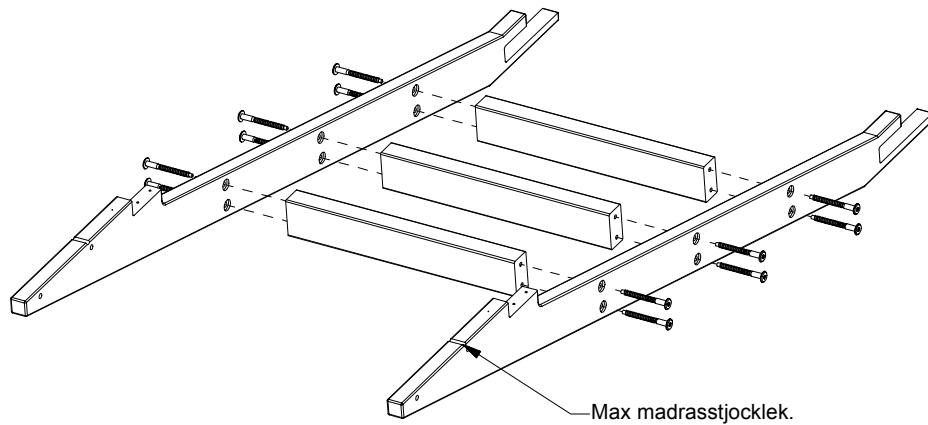

Max madrassjocklek.

16.



Kx2



Lx2

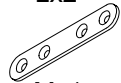

Mx1



Nx4

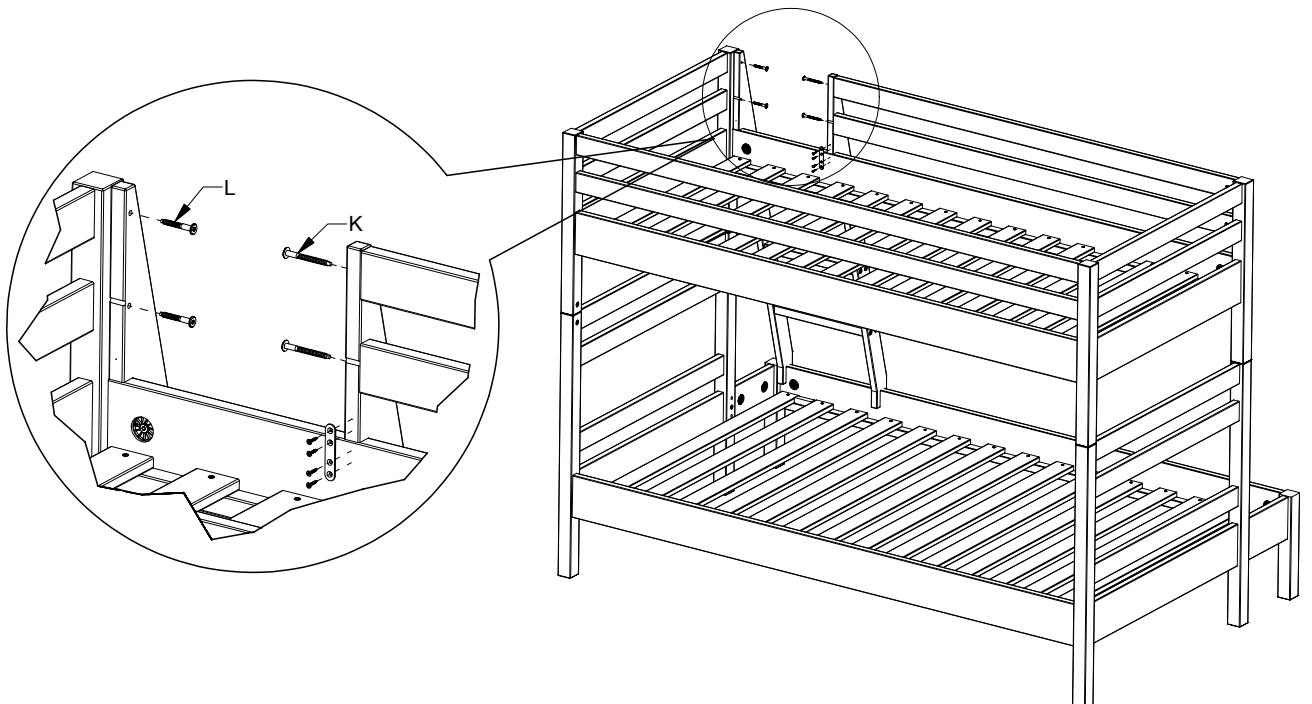

MAVIS®

Sunne Enkelsängar

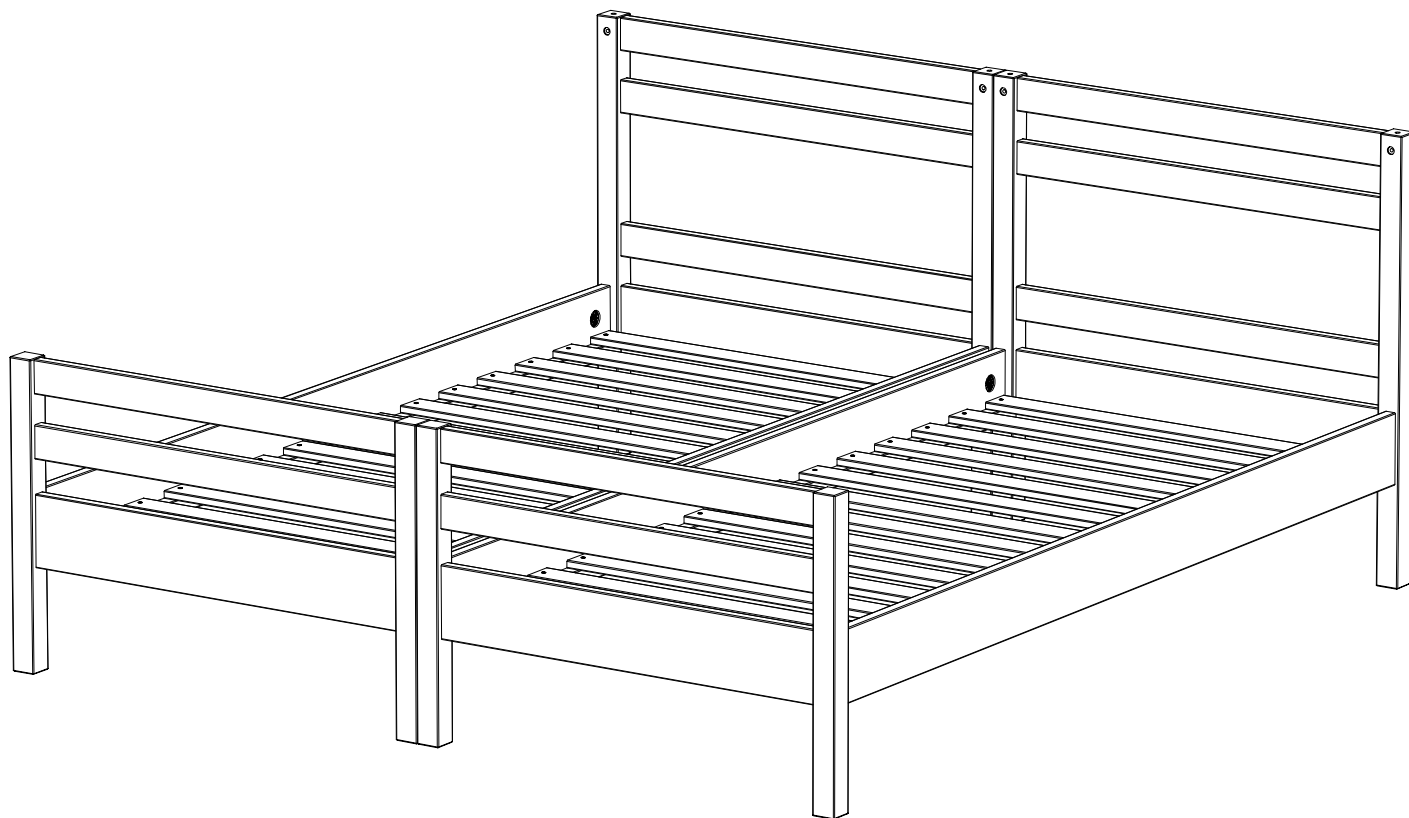

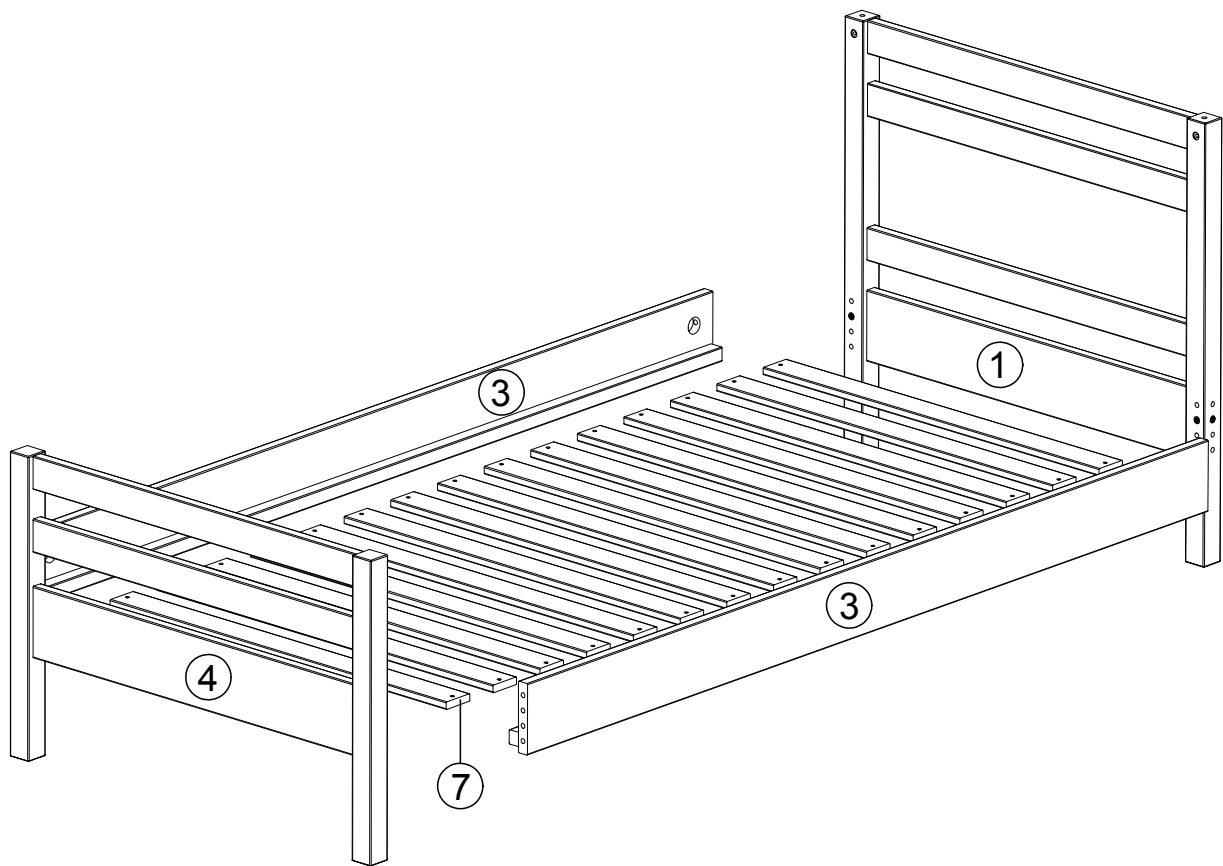

Verktysbehov

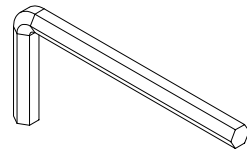
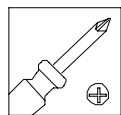

Beslag

Ax12

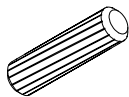

Cx4

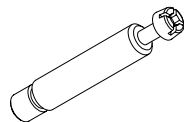

Dx4

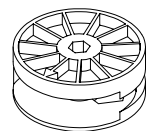

Gx30



Ox2

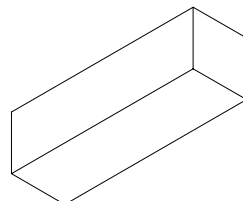

1.



Ax6



Cx2

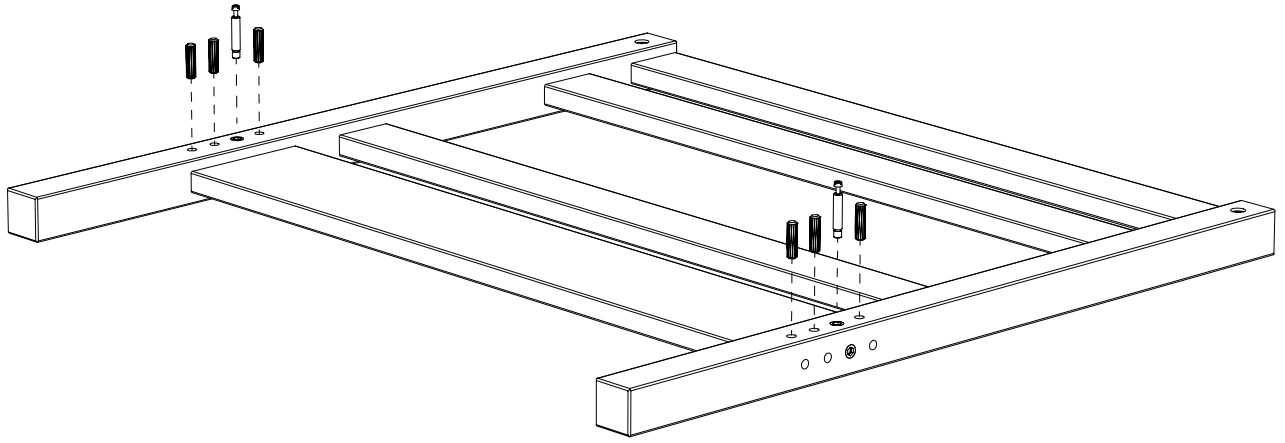

2.



Ax6



Cx2

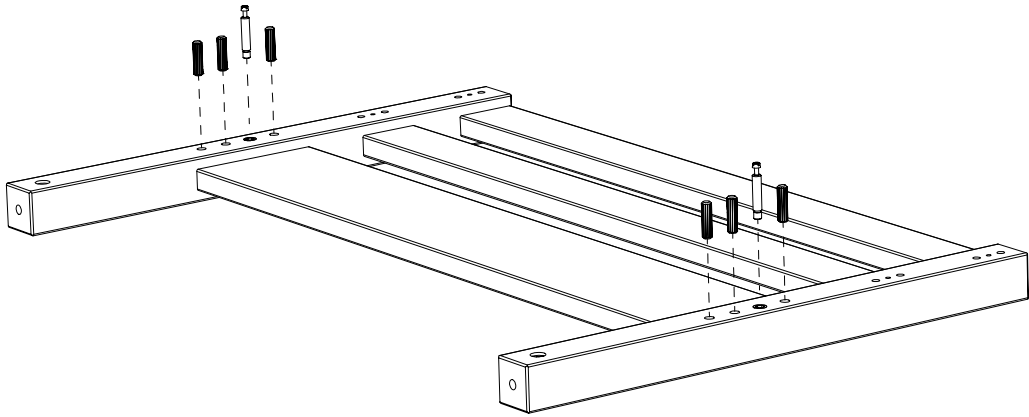

3. (x2)



Dx2

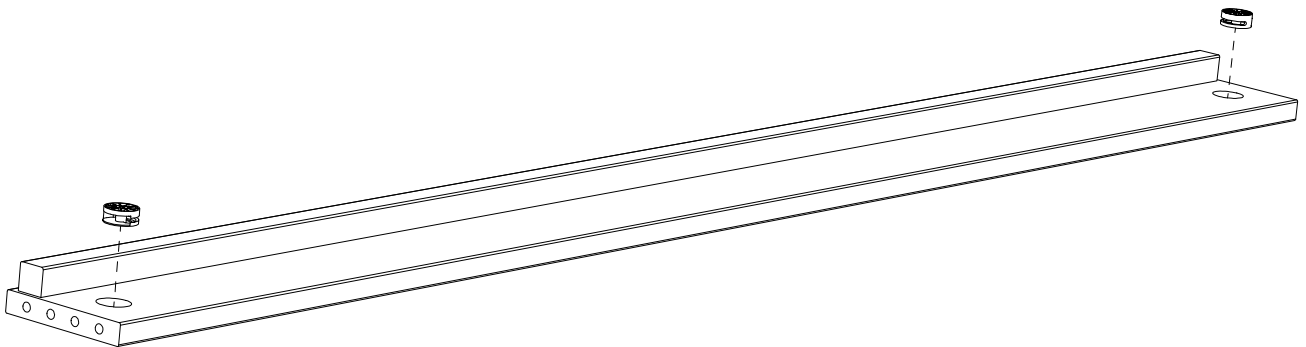

4.

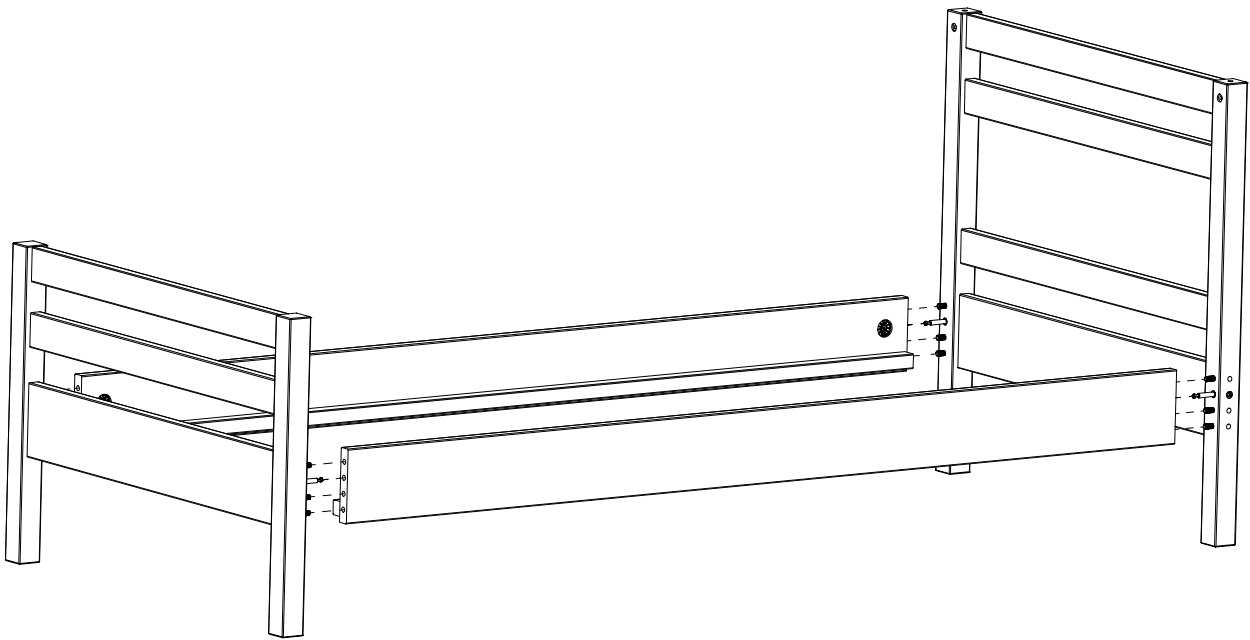

5.

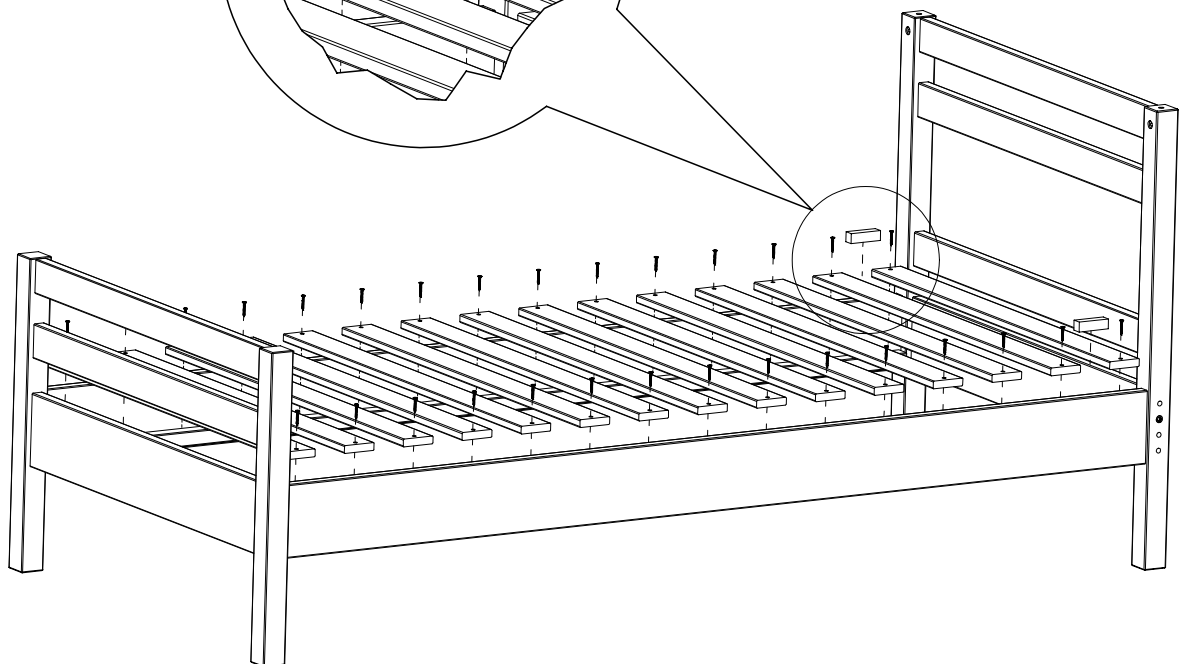
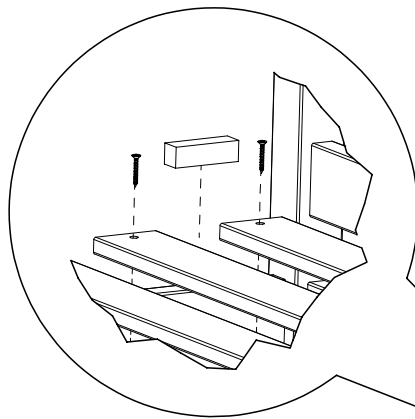
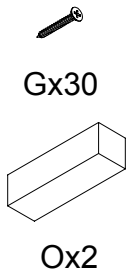

Några goda råd från oss...

- Innan du börjar använda möbelen rekommenderar vi att du torkar av alla ytor med en lätt fuktad trasa. Tänk på att vissa material kan ludda av sig, använd gärna mikrofibertrasa.
- De flesta ytor är förslutna med klarlack, pigmenterad lack eller en bets, men är mer eller mindre känsliga mot lösningsmedel. Vi rekommenderar därför att du endast använder en mild tvällösning eller ofärgad såpa tillsammans med en ordentligt urvriden trasa.
- Undvik att placera möbelen i direkt starkt solljus.
- Du bör använda ett underlägg till heta ytor.
- Undvik att placera stearinljus direkt på möbelytan.
- Om du har ett repkänsligt golv och möbelen är avsedd att stå på golvet kan det vara bra att förse produkten med möbeltassar.
- Torka genast upp vätskor om du spillar.
- Både klara, betsade samt målade träytor åldras med tiden och skiftar i färg. Kvistar är en del av träprodukten.
- Vi rekommenderar att du med jämna mellanrum kontrollerar skruvar och fästordningar och justerar eller efterdrar efter behov. Spar därför anvisningar och rekommendationer.
- Lukt kan förekomma när du först packar upp produkten. Detta beror på att ytan härdar ut efter emballering. Lukten försvinner fortare från möbelen om man torkar av alla ytor med en fuktig trasa. Det kan vara bra att låta lådor lufta ur ett dygn före användning.
- Metallsvärtning (liknande blyertsstreck) kan uppstå på lackerade ytor exempelvis från smycken, nycklar, bitar eller dragkedjor. Strecken tar du enkelt bort med ett vanligt ofärgat radergummi.

p.s vill du komma i kontakt med oss så kika in på mavis.se
hörs snart igen...

/Tack från alla oss på Mavis