



StableTable® assembly instructions

All StableTable bases come assembled. The only thing you need to do is to attach the FlexCross™ or FlipTop™ mechanism to the centre pillar with one screw.

With each top-cross and mechanism there is one (1) M6 Insex screw and one (1) washer supplied.

Place the top-cross/mechanism with the orange marked nudge in the cut-out on the centre pillar and fix it with the screw and washer and pull tight.

Please note that each centre pillar has two cut-outs. Recommended fixing is with the nudge placed in the cut-out positioned between two of the cross legs so that the legs will go from corner to corner on a square top.

If you are using the Hook and Handle accessory kit, this should be fixed after the top has been attached to the folding mechanism.

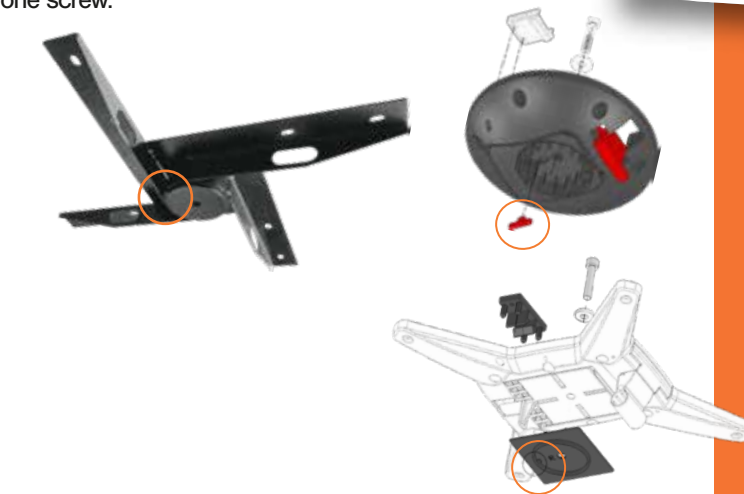

Hook & Handle accessory kit for FlipTop Mechanism
Round and X-shaped (sold separately)

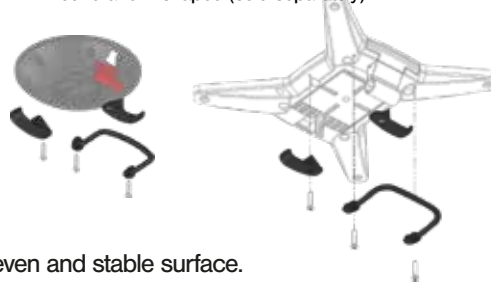

Attaching the table tops to the bases

1. Place the table top upside down on a clean, even and stable surface.
2. Place the StableTable base upside down in the centre of the table top and so that the cross legs of the base are placed on a square top as shown in the below pictures.



Recommended



Not recommended

3. For wood or composite table tops, always use ordinary wood screws when fastening the table top. Using the wrong screws may lead to the screws loosening themselves. For compact laminates, use screws as recommended by the supplier of the table top.
4. StableTable only supply screws if agreed and if bases and the tops are supplied together.
5. The screws must be of the right length otherwise they might pull through the table top. For wood and composite table tops it is recommended that the length of the screws is approx. 70-75% of the thickness of the table top plus the build of the cross. For compact laminates the screws should be the length as recommended by the supplier of the table tops plus the build of the cross.
The StableTable FlexCross™ build approx. 2 mm.
The StableTable FlipTop™ folding mechanisms build approx 12 mm.

To be noted before fixing the table tops to the table bases

- If tops with pattern or logo - decide how you want the these to "appear" and consider this when fixing the top to the base.
- Always try to mount the table bases so that the adjustable legs are in the same direction on all tables - this makes it easier when placing the tables next to each other.
- When using an electric screw driver, ensure that the torque is not set to high to avoid that the screw holes are pulled round.
- Always ensure that the adjustable feet are tightened as tight as possible. Under normal conditions you will never adjust the feet, they are there to protect your floor.